

MODULINE COLORSCREEN FENCING

A2

Experienced Contractors Installation Method

Tools Required:

- 1) Variable speed electric drill or battery drill set on higher speed setting
- 2) Pocket Knife or dinner knife (with strong blade).
- 3) Pair of vice grips or C-clamp vice grips
- 4) Reliable level (Stanley magnetic levels are cheap and accurate)
- 5) 1x Phillips No.2 bit for drill (50 to 70mm long)
- 6) A rubber mallet (optional)
- 7) 2x Stretchies (supplied)
- 8) 1x Pair Gloves

DAY ONE:

Step 1 - Set a string line up along the proposed fence line. This should be at the height that the fence will sit off the ground. The string line should be on the side that you will be working on. Allow for the 60mm over-all width of the fence, 65mm for Heavy Duty posts.

Step 2 - Mark out the fence post centres. Use precise markers (i.e. 100mm nails) to mark the 2.42 m panel post to post centres. In any length of fence there will normally be a short panel to finish off.

Step 3 - Temporarily remove the string-line to dig the holes. Holes should be a minimum of 200 x 200 x 600 deep. If using a post-hole borer, use a 200mm auger or larger.

Step 4 - Reset the string-line. Remember you are stringing the equivalent of the underside of the bottom rail which should be approximately 60mm off the ground.

Step 5 - Lay out one bottom rail and two posts alongside each hole. Screw the two posts back to back using 3x tek screws. Beside the first and last hole lay only one post.

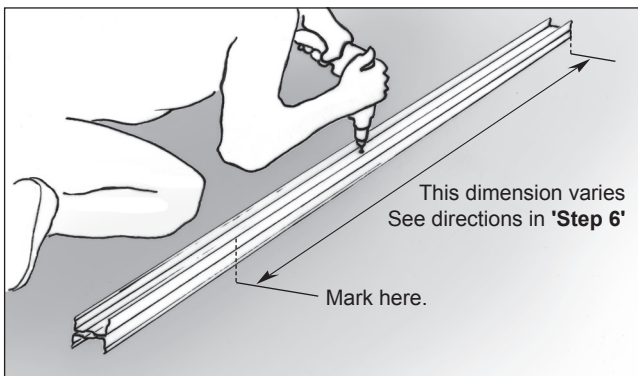

Step 6 - Mark the side of the posts with a crayon to set the finished height above the string-line. For example: For a 1.8 high fence on a level site, mark down from the top 1740mm (1720 +20 for the cap).

For a sloping site, mark down 1760mm from the top. The table below details the dimension for each fence height.

Fence Height Dimensions			
Fence Height	Duopanel Length	Height Above Stringline on Near Level Sites	Height Above Stringline on Sloping Sites
2.0m	1.99m	2.02m	2.04m
1.8m	1.71m	1.74m	1.76m
1.5m	1.41m	1.44m	1.46m
*1.2m	1.17m	1.22m	1.22m
1.2m	1.11m	1.16m	1.16m
0.9m	0.81m	0.86m	0.86m

*The 1.17m Duopanel is used where 1.2m high Colorscreen fencing is required for pool safety fencing or to match 1.2m high Poolside Fencing.

Step 7 - Set up the first post. This may be concreted into the ground or fixed to a building or existing fence. It is important to get this post plumb and have the crayon height-line matching the string-line.

Step 8 - Tek screw a bottom rail to the first post so that the underside of the bottom rail is level with the crayon mark and string-line (as illustrated).

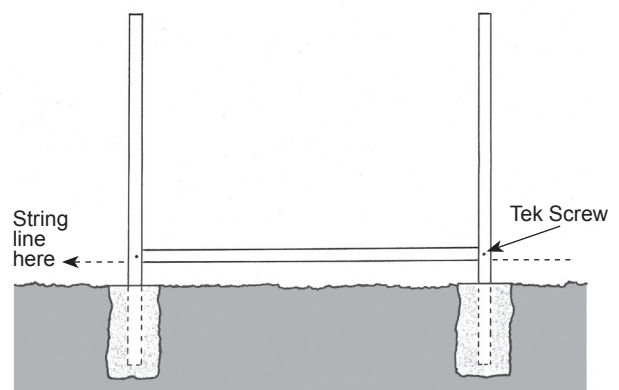

METAL ROLLFORMING LIMITED

PO BOX 18-217, AUCKLAND 1743, PHONE (09)527-7897, FAX (09)527-7896

Experienced Contractors Installation Method (cont'd)

A2

Step 9 - Insert a screwed double post on the other end of the rail again lining up the crayon mark with the underside of the rail.

Check that the distance from the outside of the first post to the centre of the double post is 2420mm and then tek screw.

Concrete the post in plumb in all directions and match the crayon mark to the string-line. Placing blocks of timber under the bottom rail may assist until the concrete starts setting in about 15 minutes.

Step 10 - Repeat this process until the end of the fence line. When completed and while the concrete is still wet go back over the fence line and ensure that all the posts are still plumb and that the crayon mark still matches up with the string-line.

An additional string-line for the top of the posts will help achieve a visually satisfying line.

Step 11 - View the side of the fence and check that the line, height and level of the fence are pleasing to the eye.

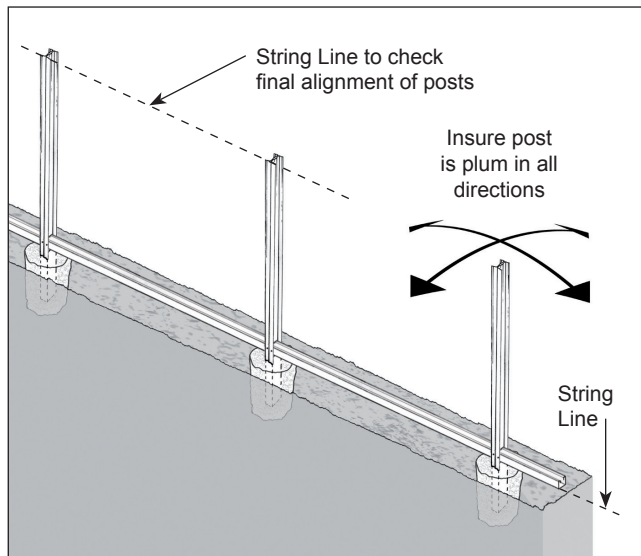

Well done! Go and get a cold refreshing drink, you've finished the hard part.



DAY TWO:

Step 12 - NEXT DAY (preferably not a windy day)

Overnight you will find that the concrete has set and all the posts will be very firm and ready for completion. Lay out a top rail beside each fence bay.

Step 13 - Commencing at the first panel, hook the Stretchie Cords (supplied) around the fence posts as shown below. These should be approximately 300mm down from the top of the posts. These will support the Duopanel before the top rail is fitted.

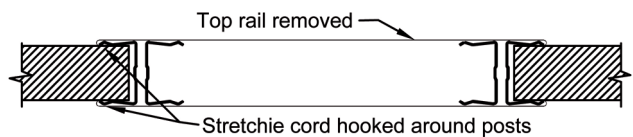

Step 14 - **IDENTIFY YOUR DUOPANELS.** For each 2.42 metre section there are 10 Duopanel made up of 1 x LH, 8 x Standard, 1 x RH. For 2 metre high with 1.94 metre wide panels there are 8 Duopanel made up of 1 x LH, 6 x Standard, 1 x RH.

Start off with either the Left-hand Duopanel or Right Hand. Establish which way around you desire the ribs on the panels to face (this is important). Most people feel that the ribbed is the better side. Lay out your Duopanel beside each bay.

Step 15 - Open up the folded seams at the ends of the Duopanel with a knife as shown below.

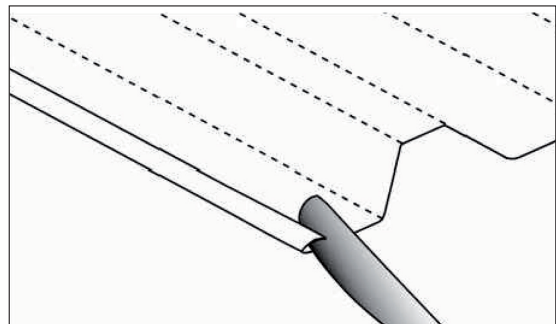

Step 16 - Starting at one side slip the first Duopanel into the bottom rail (LH or RH panel). Ensure that the top of the Duopanel is between the stretchies.

To get the Duopanel to slip into the bottom rail you may have to tap the top with the handle of your hammer or a rubber mallet, or alternatively use the palms of your hands on either side of the Duopanel and apply downward pressure until the panel slips in the bottom rail.

METAL ROLLFORMING LIMITED

PO BOX 18-217, AUCKLAND 1743, PHONE (09)527-7897, FAX (09)527-7896

Experienced Contractors Installation Method (cont'd)

A2

Step 17 - Slide the next Duopanel (standard panel), down the seam starting from the top so that the two Duopanel are locked together. As you slide the panels together, make sure the panels are square.

The easiest way to do this is to pull the panel from the bottom, while holding it square at the top with your other hand. It is advisable to WEAR GLOVES.

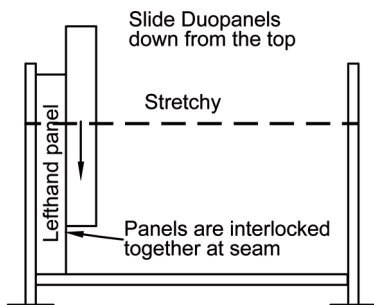

Step 18 - Repeat Step 17 with the remaining Duopanel, finishing with the LH or RH panel remaining (10 in all per 2.42 metre section).

Step 19 - Put the top rail onto the Duopanel. Start by angling the top rail to one end and slowly work the rail over the panels as you lower the rail.

Set a string-line out for the top rails to ensure a nice line when screwing the top rails in position.

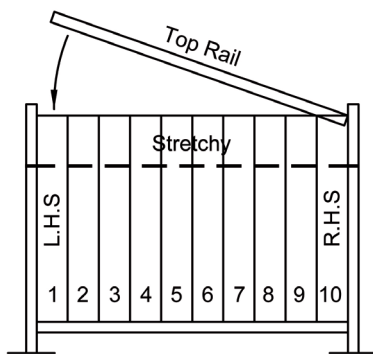

Note: Only 8 Duopanel for 2.0 metre high fencing.

Step 20 - Repeat Steps 14 to 19 until all the Duopanel have been installed in your fence line.

Step 21 - Finish your fence with the plastic post caps supplied. When fitting the supplied caps either flare the post ends to give the caps a tighter fit or tek-screw the cap on one side.

PLEASE NOTE DO NOT USE AN ANGLE GRINDER OR ABRASIVE CUT OFF BLADES WHEN CUTTING COLORSTEEL.

GENERAL NOTES:

Assembling Shorter Length Panels

Many fences will require one or more shorter length panels to make up the desired fence length. You will need to cut down the rails and possibly also the duopanel to achieve this.

Step 1 - Cut the Rails to desired length using a hacksaw. File the cut to remove burrs, then wipe swarf off inside and outside of rail with a soft cloth.

Step 2 - If a whole number of Duopanel will not fit, you may need to trim a duopanel to make up the desired width. This can be achieved by one of three ways:

(A) The easiest and neatest option is to score with a Hardies tungsten scoring knife and hand fold the Duo Panel which will then snap off at the scored width. Hardies scoring knives are available for around \$12 from most hardware outlets.

(B) Take the Duopanel to your local sheet metal workshop for guillotining.

(C) Cut down with tin snips.

Step 3 - For short panels using up to 3 Duopanel (or 0.74 metres wide) use only standard Duopanel and not LH or RH Duopanel.

High Wind Areas: COLORSCREEN fences are designed for high wind zones. Fence posts are made from high tensile steel and heavy duty posts are used for fences over 1.5 metres high.

Extreme High Wind Areas: In very high wind areas the post centres may have to be reduced. Please discuss this with Moduline.

METAL ROLLFORMING LIMITED

PO BOX 18-217, AUCKLAND 1743, PHONE (09)527-7897, FAX (09)527-7896