

# MODULINE COLORSCREEN FENCING

**J**

## Change in Fence Heights via a sloping panel

**Step 1** - Install all your fence frames as per Instruction Sheet A, with the exception that the width of the sloping panel frame is only 2.18m.

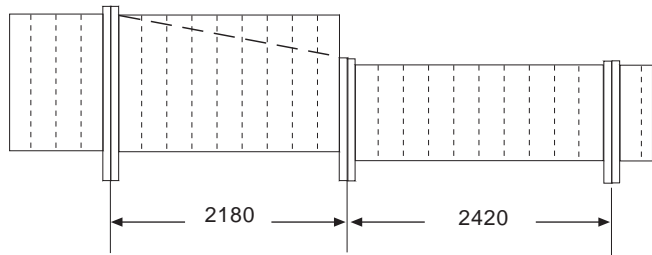

**Step 2** - Insert all the duopanel as per Instruction Sheet A, bearing in mind that all full length panels have 10 duopanel, but the sloping panel will only have 9 duopanel (7 x standards, 1 x LH and 1 x RH). Support duopanel with the stretchies supplied.

**Step 3** - Take a straight edge and a felt tip pen and mark the angle on the fence. Be sure to mark each individual duopanel. these marks will be hidden by the top rail.

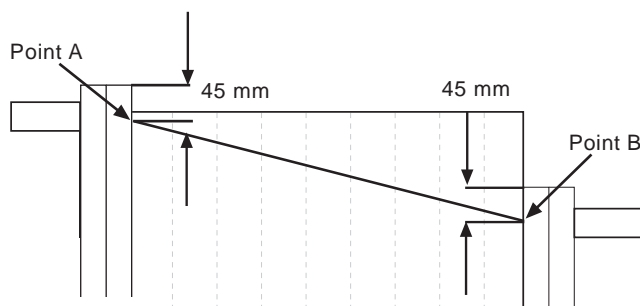

Make sure each panel is marked with a felt tip pen.  
The line should run from Point A to Point B

**Step 4** - Dismantle the sloping panel and cut each individual duopanel with tin snips along the felt tip line.

**Step 5** - Re-assemble the cut duopanel and cut a 2.4 top rail to length of slope. Cut the rail with a plumb cut to suit the angle.

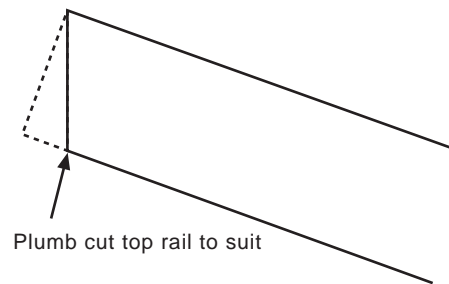

**Step 6** - Complete tek screws and fit caps to fence.

### METAL ROLLFORMING LIMITED

PO BOX 18-217, AUCKLAND 1743, PHONE (09)527-7897, FAX (09)527-7896