

# MODULINE POOLSIDE FENCING

U

## Assembling Panels with Sloping Top Rail

**Step 1** - Assemble 19mm square bars into pool channel as per normal but do not tap the top pool channel down further than 5~10mm.

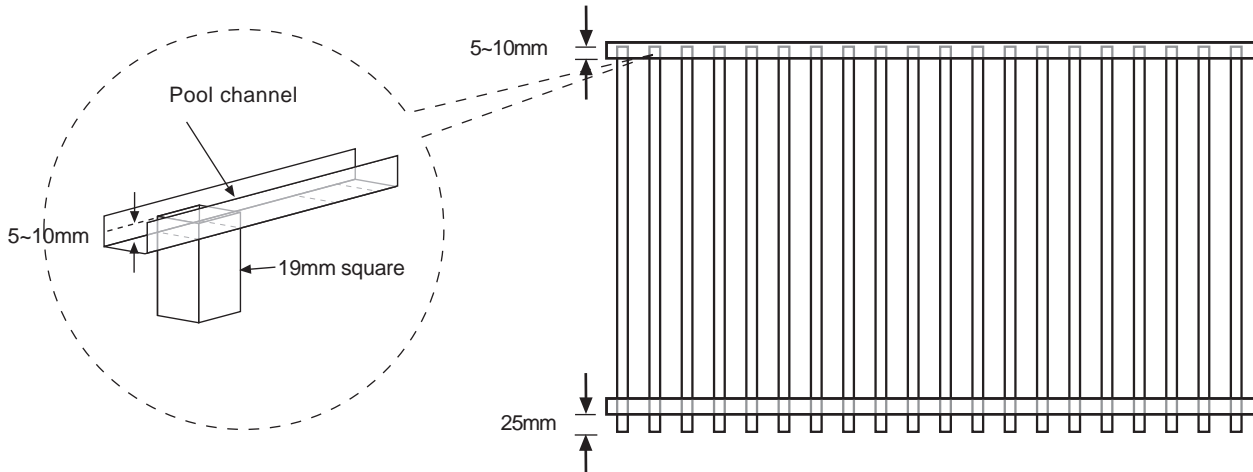

**Step 2** - Now place threaded bars carefully onto two saw stools with timber between as specified in instruction sheet L, **step 1**  
Ensure panel is square (Diagonal measurements are equal)

**Step 3** - Lay 13mm angle supplied across bars to required angle. Tek screw this 13mm angle at each intersection point of the vertical bars for the full panel.

**Step 4** - Now cut off the excess 19mm square bars from 10~20mm above the angle using a hacksaw. Then slide rails onto panel as per normal assembly instructions and complete assembly of panel.

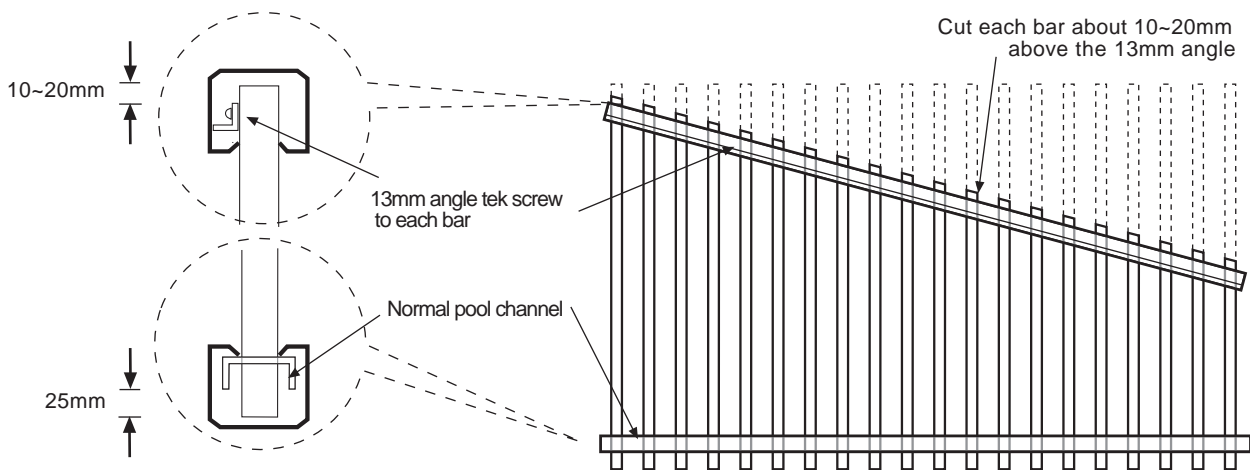

**METAL ROLLFORMING LIMITED**

PO BOX 18-217, AUCKLAND 1743, PHONE (09)527-7897, FAX (09)527-7896